

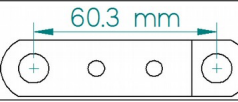



09 ATEX Fire Failsafe Unit with Gearbox or Lever

Table 1 Model	Yield temperature	Ambient temperature range	Max surface temperature	Fusible link type
09++0*0-1211	72°C	-40°C to 42°C	42°C	 Type "A" Pre 02.2019
09++0*0-1214	93°C	-40°C to 63°C	63°C	 Type "B" Post 02.2019
09++0*0-1074	74°C	-40°C to 38°C	38°C	
09++0*0-1100	100°C	-40°C to 66°C	66°C	

<b>KEY: ++ Will be one of the following:</b> 4 - / 0 - = ISO Male Drive 3F = ISO Female Drive 7 - / 9 - = ANSI Male Drive 7F = ANSI Female Drive 3S = ISO Serrated Female Drive** 7S = ANSI Serrated Female Drive**	<b>* Will be one of the following:</b> 2 = Clockwise spring action 3 = Anticlockwise spring action	 <b>**Typical serrated inserts</b>
---	--	---

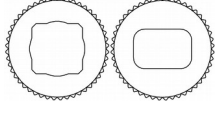
**KINETROL** GU9 8NU UK  
 TYPE: XXXXXXX-1XXX  
 Ser. No: xxxxxxxx

**Ex** KINETROL 23.0118X  
 II 2GD  
 Ex h IIC TX Gb  
 Ex h IIC TXX°C Db  
 -40°C ≤ Ta ≤ XX°C

**CE \*\*\* UK CA**  
 20\*\*  
 P max = 7 bar (100psi)

Where possible the Fire Failsafe unit should be used in conjunction with a gearbox as the method of loading. Alternatively a lever can be used, but great care must be taken to avoid injury or damage.

**WARNING – KEEP OUT OF SHADED ZONE SHOWN BELOW DURING LOADING AND IN USE.**

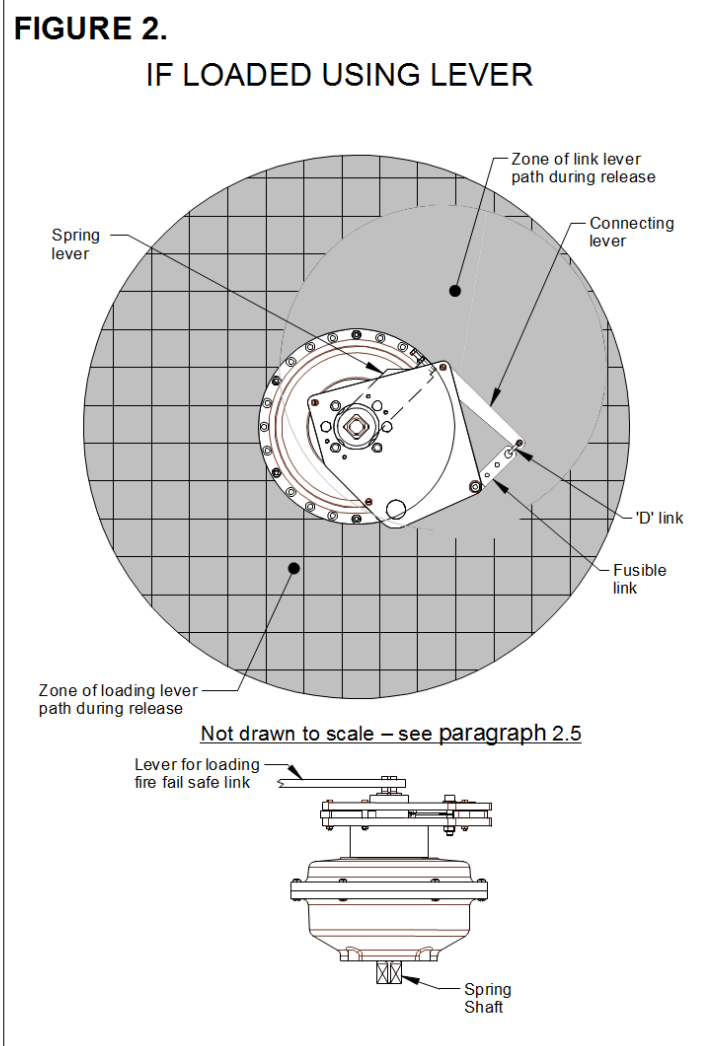
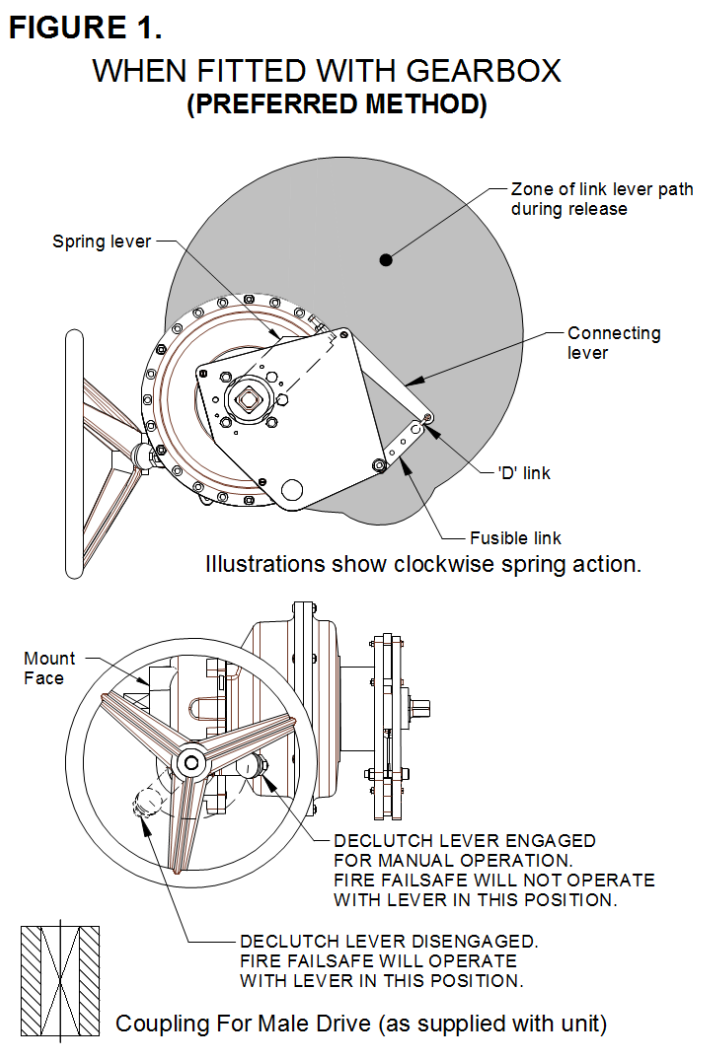

**1.) INSTALLATION**

- 1.1) Fit unit to bracket/valve with coupling to valve stem.
- 1.2) Ensure that coupling (if fitted) can be moved without much effort, such that it does not side load valve stem or spring shaft.
- 1.3) Refer to Kinetrol TD111 for recommended screw tightening torques.
- 1.4) Ensure that the unit is installed in a position which allows access to the handwheel or lever.
- 1.5) Fail-safe link should not be painted or covered and be free from grease and dirt

**1.6) Ensure unit is earthed.****2) OPERATION**

- 2.1) Operating conditions:
  - Angle of travel 90° (Non-Adjustable)
  - Max vibrating conditions: 4g@100Hz
  - Fail safe yield temperature: and ambient temperature range: See table 1.
- 2.2) If using Gearbox\*\*\* see 2.3. and 2.4. If using lever see 2.5 and 2.6. \*\*\*Note: Gearbox must be ordered separately.
- 2.3) Load the Fire Fail-safe by moving Gearbox declutch lever to “handwheel engaged” position and turning handle (see TD185), so that spring lever rotates past the connecting lever (normally 90°) just enough to allow the ‘D’ link to be fitted between the connecting lever and the fusible link.
- 2.4) Insert the ‘D’ link through the fusible link and connecting lever and tighten. Turn handwheel in reverse until there is no slack in the fire failsafe link assembly. Carefully move gearbox declutch lever to '**HANDWHEEL DISENGAGED**'.

**GEARBOX DECLUTCH LEVER MUST BE IN “HANDWHEEL DISENGAGED” POSITION FOR THE FIRE FAILSAFE TO OPERATE.**

- 2.5) Load the Fire Fail-safe by fitting a suitable lever (suggested length = 1143mm/45”) to the top square. The task requires two people, one to control the spring, the other to connect the links. The person connecting the links **MUST** stand outside the spring release zone to prevent injury if the spring arm is accidentally released before it has been latched.
- 2.6) Rotate lever (normally 90°) slowly with a good grip and ensure that there is nothing in the path of an accidentally released lever. **DO NOT RELEASE LEVER DURING LOADING.** Insert the ‘D’ link through the link lever and tighten. Gently release the lever and remove from square.

**REMOVE LEVER AFTER LOADING – FAILURE TO DO THIS MAY RESULT IN INJURY OR DAMAGE.**

- 2.7) The link is now loaded. To remove the link tension, follow this procedure in reverse.

**3) MAINTENANCE**

- 3.1) The Fire Fail-safe link should be inspected twice annually and renewed annually. Fire Fail-safe link can be replaced by removing the link tension (as described in 2.7) and removing the pivot pin. A suitable replacement can be obtained from Kinetrol.

Quote serial number as printed on spring label.

Kinetrol document TD 221 specifies the fusible link and connecting lever combination required for replacement.

- 3.2) If the spring operation has to be checked it must be done as follows:
  - a) If fitted with gearbox move the gearbox declutch lever to “handwheel engaged” position and turn handle (see TD185), so that spring lever rotates just enough to allow the ‘D’ link to be removed. Remove ‘D’ link. Turn handwheel in reverse, allowing spring to unwind until the spring lever locates on the travel stop. On completion of check, follow paragraphs 2.3 & 2.4 to reset the unit.
  - b) If NOT fitted with gearbox fit suitable lever to square, pull against spring action until fire fail-safe link can be disconnected, then **SLOWLY** allow the spring to unwind until the spring lever locates on the travel stop. **DO NOT RELEASE THE LEVER SUDDENLY, AS THIS MAY RESULT IN INJURY OR DAMAGE.** The same safety precautions should be applied to releasing the unit as to latching it in position. See also paragraphs 2.5 & 2.6.
- 3.3) The spring unit does not contain user serviceable components. If the spring is faulty it should be disposed of safely and replaced with a new unit or returned to Kinetrol for repair.
- 3.4) DO NOT allow dust to accumulate clean only with a damp cloth to prevent over heating, DO NOT rub.

**4) MATERIALS OF CONSTRUCTION**

Spring housing – Aluminium Alloy Epoxy stove enamel,  
Fusible link (Type B) – Bronze with eutectic alloy solder.  
Cover plate and link lever – Stainless steel.