

# Title: Installation and Operating instructions for G3 Damper Drives

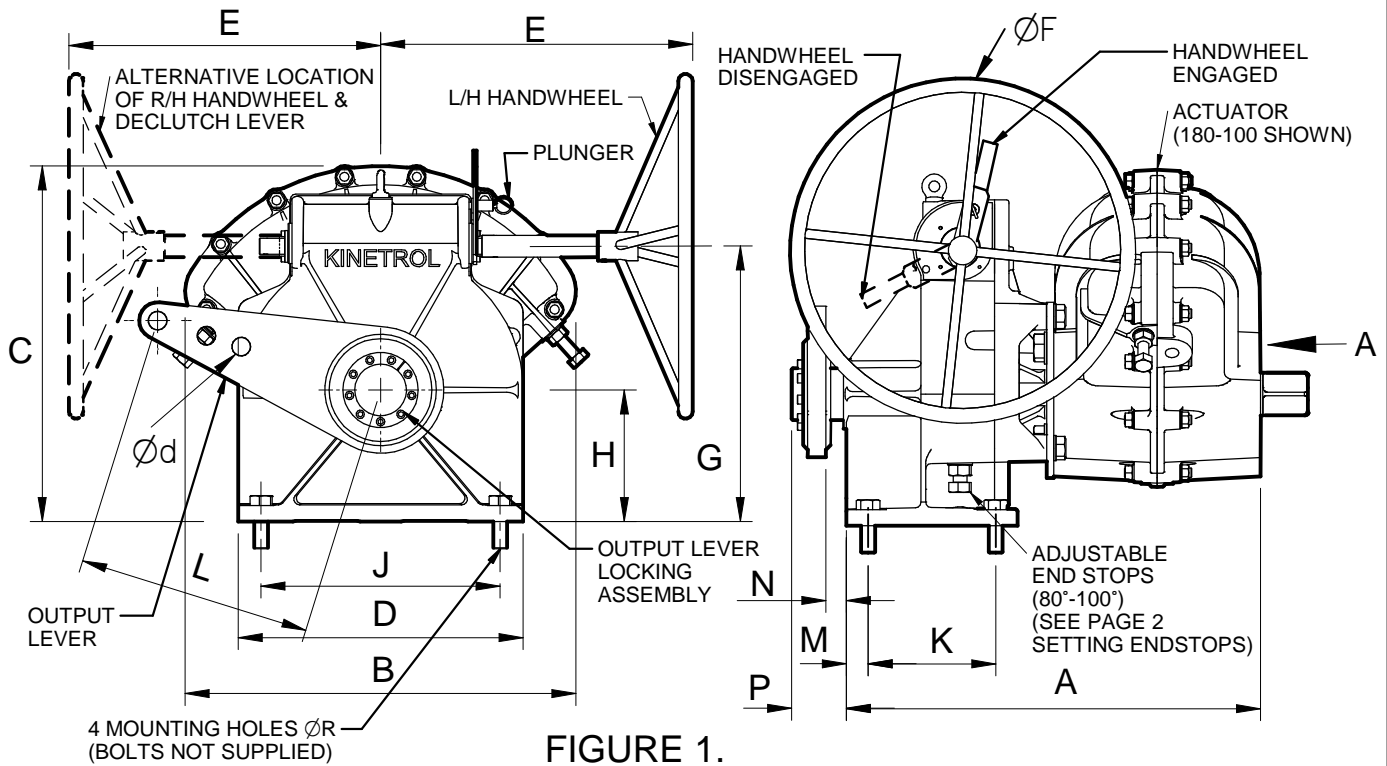

FIGURE 1.

## PRINCIPAL DIMENSIONS (mm)

MODEL	A	B	C	D	E*	ØF*	G	H	J	K	L*	M	N#	P	ØR	WEIGHT
124	366	294	336	275	205	300	300	165	216	152	300	25	13-32	70	21	46 kg
144	410	380	390	275	300	300	300	165	216	152	300	25	13-32	70	21	46 kg
164	495	530	470	275	330	400	300	165	216	152	300	25	13-32	70	21	51 kg
184	721	680	620	496	430	760	479	229	416	222	406	38	19-45	94	27	141 kg
204	981	680	620	496	508	600	479	229	416	222	406	38	30-38	94	27	158 kg

## PRINCIPAL DIMENSIONS (inches)

127	14.4	11.6	13.2	10.8	11.0	12.0	12.0	6.5	8.50	6.00	12.0	1.0	1.0-1.3	2.8	0.83	102 lb
147	16.2	15.0	15.4	10.8	12.0	12.0	12.0	6.5	8.50	6.00	12.0	1.0	1.0-1.3	2.8	0.83	102 lb
167	19.5	20.9	18.5	10.8	13.0	16.0	12.0	6.5	8.50	6.00	12.0	1.0	1.0-1.3	2.8	0.83	112 lb
187	28.4	26.8	24.4	19.5	17.0	30.0	18.9	9.0	16.38	8.74	16.0	1.5	1.2-1.5	3.7	1.06	310 lb
207	38.6	26.8	24.4	19.5	20.0	24.0	18.9	9.0	16.38	8.74	16.0	1.5	0.8-1.8	3.7	1.06	350 lb

\*Dimensions shown in table for E & ØF are standard. Alternative sizes are available, see catalogue or sheet KF445.

\*For dimension L see catalogue or sheet KF445. (\*These dimensions are specified by the ordering code.)

Size & position of "d" holes and thickness "t" of lever are also specified by the ordering code.

#Dimension N is adjustable between the 2 figures shown. This is approximate only dependant on lever thickness.

Weights shown above are for the assembly **excluding** actuator.

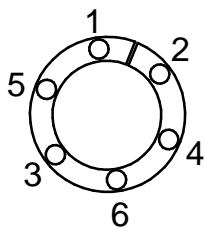
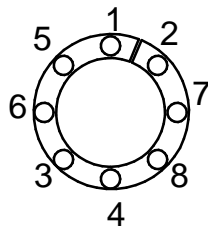
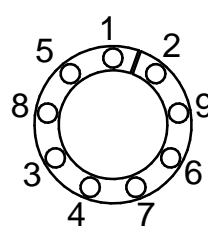

FIGURE 2.



124/127: 35Nm / 26 lb.ft.  
144/147: 35Nm / 26 lb.ft.  
164/147: 69Nm / 51 lb.ft.

FIGURE 3.



184/187: 69Nm / 51 lb.ft.

FIGURE 4.

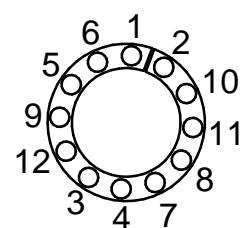

204/207: 83Nm / 61 lb.ft.

FIGURE 5.

ISSUE  
L

D.G.W.  
FEB-23

**KINETROL**

Trading Estate, Farnham, Surrey, England

Doc. No. TD 118  
Page 1 of 4

# Title: Installation and Operating instructions for G3 Damper Drives

**LIFTING:** When the assembly is NOT fitted with an actuator, the lifting eye provided can be used on its own; When an actuator is fitted, suitable slinging must be provided to support the actuator, in addition to using the lifting eye provided

**MOUNTING:** The assembly must be fitted on to a rigid, flat surface using all 4 mounting holes.

**OUTPUT LEVER:** Ensure there is adequate clearance between output lever and other parts. Therefore, whenever possible the output lever should be located on the opposite side of the assembly to the handwheel / declutch lever. **In any case the output lever should always be guarded (in accordance with local legislation) to prevent the risk of injury.**

**ASSEMBLING AND SETTING OUTPUT LEVER ON SHAFT:** Do NOT use any molybdenum disulphide between shaft / locking assembly / lever.

1. *For all models except model 204/207:* Fit screws in 3 equispaced jacking holes (fitted with plastic plugs): this prevents the front and rear rings from tilting during fitting.

*For model 204/207* fit 6 screws into the jacking holes (note that the jacking holes jack the front/centre rings & rear/centre rings alternately - hence the need for 6 screws)

2. All models: Gently tighten the remaining screws until the locking assembly is in the required position along the shaft, and the lever is at the desired angle (the "bore" of the locking assembly must be in full contact (i.e. not overhang) with the shaft, and the outside of the locking assembly must be fully enclosed by the lever hub). Remove the jacking screws and fit them like the others.

3. Tighten the screws in the sequence shown in figure 2, 3, 4 or 5 as appropriate. Tighten the ring of screws in 5-6 stages, with the applied torque increasing gradually with each stage, until the final screw torque (as shown in figure 2, 3, 4 or 5 as appropriate) is achieved on every screw. At least 2 circuits are required at full torque to ensure every screw is fully tightened to specified torque. **Failure to follow this procedure may seriously damage the shaft / locking assembly.**

**REMOVAL OF LEVER:** If necessary, the lever can be removed by taking out all screws and refitting them into the jacking holes, (after removing the plugs), tightening them in the same sequence as for fitting

**CAUTION:** The output lever is heavy, and once the locking device is loosened, the lever must be supported, or it may rotate under its own weight with the risk of causing injury.

**SETTING ENDSTOPS:** Rotational travel of the drive MUST be controlled using the adjustable endstop screws on the drive body, NOT the stop screw in the actuator. Actuator stop screws should be adjusted so they do not make contact with the actuator vane. Endstops should be set to prevent over travel of output lever which could result in damage to driven device.

**OPERATING:** Do not operate the Damper Drive unless suitable safety guarding is installed.

**MOVING THE DECLUTCH LEVER:** To move the declutch lever, first pull the ring-pull to extract the plunger from its locating hole; After turning declutch lever to the required position, ensure that the plunger is fully latched into its locating hole. To Engage the handwheel, it may be necessary to slowly rotate the handwheel until gear teeth are aligned. **DO NOT** attempt to select "engaged" lever position while the Output shaft is in motion (i.e. the actuator & output lever are turning); Likewise, **DO NOT** attempt to "disengage" the declutch lever if the actuator air supply is set such that it is likely to cause the actuator to turn, thus applying a force through the manual override gears. Failure to observe the above may seriously damage the unit.

**MANUAL OPERATION:** To operate the assembly manually, the Declutch lever must be latched in the "Handwheel Engaged" position. When unit has "Left Hand" Handwheel (see Figure 1 on page 1), clockwise rotation of handwheel produces counter-clockwise rotation of shaft/output lever when viewed from arrow "A". When handwheel is fitted to "Right Hand" side, clockwise rotation of handwheel produces clockwise rotation of shaft when viewed from arrow "A"

**IMPORTANT:** The handwheel provided is sized such that a rim force of 125lbs should be sufficient to produce full rated output torque; **DO NOT** use extra levers on handwheel to increase the handwheel torque, as this may seriously damage the unit.

ISSUE L	D.G.W. FEB-23	<b>KINETROL</b>	Trading Estate, Farnham, Surrey, England	Doc. No. TD 118 Page 2 of 4
------------	------------------	-----------------	--	--------------------------------

# Title: Installation and Operating instructions for G3 Damper Drives

**PNEUMATIC OPERATION** (using actuator): The declutch lever must be latched in the "Handwheel Disengaged" position.

**FITTING ACTUATOR:** Firstly, the "actuator plate" should be fitted to the actuator; Actuator plates are symetric front/back and side/side, but not top/bottom, so ensure that the plate is fitted to the actuator such that the actuator will be the right way up when fitted to the main gearbox (as shown in fig.1) as follows:

1. The 4 (8 on model 204/207) actuator fixing screws "A" should be coated with thread locking fluid, and tightened to the torque shown in figure 6.
2. Establish whether the actuator shaft is set to its CW end, mid , or CCW end of travel. Locate the handwheel to its "engaged" position, and, using the handwheel, drive the output shaft so that its square hole is aligned with the actuator square. Using suitable lifting equipment, lift the actuator and engage its shaft fully into the Damper Drive shaft.
3. The 4 "B" fixing screws should be coated with thread locking fluid, inserted through the corner holes in the actuator plate, and screwed into the tapped holes\* on the rear of the damper drive. If necessary, turn the handwheel to align the holes. (\* model 164/167 uses nuts instead of tapped holes. Note that it is necessary to declutch the lever in order to fit one of the upper screws. 4 spacers (provided) must be fitted between the actuator plate and the gearbox plate). Tighten the screws to the torque shown in figure 6.

MODEL	SCREW "A"		SCREW "B"	
	SIZE / LENGTH	TORQUE	SIZE / LENGTH	TORQUE
124	M12 x 30mm	104Nm	M12 x 35mm	62Nm
144	M16 x 35mm	210Nm	M12 x 35mm	62Nm
164	M24 x 45mm	570Nm	M16 x 70mm	145Nm
184	M30 x 60mm	1050Nm	M24 x 50mm	350Nm
204	M30 x 60mm	980Nm	M24 x 50mm	641Nm
147	5/8UNC x 1.25"	159 lb.ft	1/2UNC x 1.25"	47 lb.ft
167	7/8UNC x 1.75"	384 lb.ft	5/8UNC x 2.75"	105 lb.ft
187	1.1/8UNC x 2.25"	739 lb.ft	7/8UNC x 2.0"	237 lb.ft
207	1.1/8UNC x 2.25"	683 lb.ft	7/8UNC x 2.0"	407 lb.ft

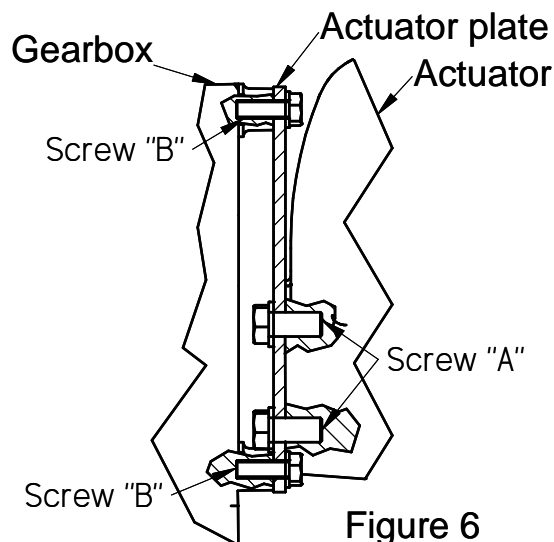

Figure 6

**REMOVING ACTUATOR:** Removal is basically the reverse of fitting. It is recommended that the handwheel is engaged before the actuator is removed. If the handwheel is not engaged, the output lever must be supported, or it may be free to rotate under its own weight, with the risk of causing injury.

**CHANGING SIDE OF HANDWHEEL:** If required, the handwheel and declutch lever can be re-located to the other side of the damper drive as follows: (For all models except 204/207):

- 1) Remove the pin attaching the "handwheel extension shaft" to the "worm shaft", and remove the extension shaft / handwheel assembly.
- 2) Undo the 2 screws holding the declutch lever on (and -model 184/187 only- the 2 screws fixing the "worm shaft retainer" ring on the opposite side of the damper drive).
- 3) Using thread lock fluid on the screws, refit the components to the required sides of the unit.
- 4) Refit the handwheel assembly to the new declutch side of the unit. (Note: model 184/187 only. It is important to perform this procedure in the 1,2,3 order stated, so that the worm shaft is at all times fully axially located by the declutch lever and retaining ring while the handwheel is being removed and refitted.

ISSUE L	D.G.W. FEB-23	<b>KINETROL</b>	Trading Estate, Farnham, Surrey, England	Doc. No.TD 118 Page 3 of 4
------------	------------------	-----------------	--	-------------------------------

# Title: Installation and Operating instructions for G3 Damper Drives

## NOTES RELATING TO ATEX APPROVED UNITS

1) Certain versions are certified ATEX category 2. Such units are identified by a label (see below) located immediately below the main gearbox identification label. If no such label is present, the unit is not ATEX approved.

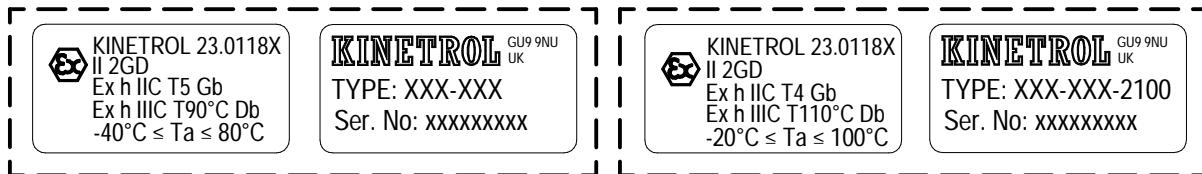

Figure 7.

Figure 8.

Assemblies fitted with the above label, for use at normal temperatures, are suitable for use in Hazardous Areas as stated on the label.

Assemblies fitted with the above label, for use at higher temperatures, are suitable for use in Hazardous Areas as stated on the label.

2) If the assembly is fitted with auxiliary modules, such as limit switch box, clear cone monitor or positioner, these modules may be certified, possibly to a different level of approval, specific to that module. Refer to the label and I.O.M. instructions for that module.

3) Materials of construction of major components:

Description	Material	Size Range
Body	Aluminium alloy, painted	12-20
Back plate	Mild steel, painted	12-20
	Aluminium alloy, painted	18-20
Actuator plate	Mild steel, painted	12-20
Main shaft	SG iron, plated	12-20
Worm shaft	Carbon steel, plated	12-20
Fixings	steel	12-20
Declutch lever	Stainless steel & Antistatic PVC	12-20
Lifting eye	steel, painted	12-20
Handwheel 12Ø Handwheel 16Ø+	Aluminium alloy, painted	12-14
	Mild steel, painted	16-20
Handwheel extension	Mild steel, plated	12-20
Shaft locking assembly	steel, natural	12-20
Output lever	steel, painted	12-20
Reduction gearbox	Aluminium alloy housing / steel gears & shafts	20

In case spare parts are required, contact Kinetrol.

4) The G3 Damper drive can be used in indoor or outdoor environments, within the temperature range specified on the label as shown in note 1, above.

5) The output lever is supplied with one or more holes, any of which can be connected to drive a linkage. The minimum radius at which these holes can be located is as shown in figure 9. Levers should not be modified to reduce dimension r to less than that shown in figure 9, as this may seriously damage the unit.

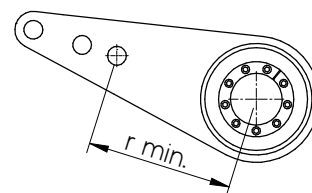

model	minimum radius r
12	4" 102mm
14	4" 102mm
16	5" 127mm
18	6" 152mm
20	10" 254mm

Figure 9.