

Kinetrol AP Positioner



ATEX Up to Category 1

Operation

The AP Positioner is designed to drive a rotary or linear actuator to a position set by a 3-15 psi (0.2 to 1.0 bar) signal and hold it there until the signal changes. When a signal pressure is applied to the diaphragm it moves the force balance lever clockwise against the tension of the feedback spring. This moves the spool valve, supplying air pressure to one side of the actuator while exhausting trapped air from the other side. The feedback shaft follows the movement of the actuator and turns the cam counter clockwise, pushing the cam follower and increasing the tension on the feedback spring until it balances the forces on the diaphragm and moves the spool valve to its hold position.

The input signal and desired position is determined by the cam profile. A cam giving 0-90° output movement linearly proportional to a 3-15 psi (0.2-1.0 bar) signal is standard, and almost any desired characteristic can be supplied to order; if it cannot be found in the list of existing options contact Kinetrol.

Schematic Functional Diagram

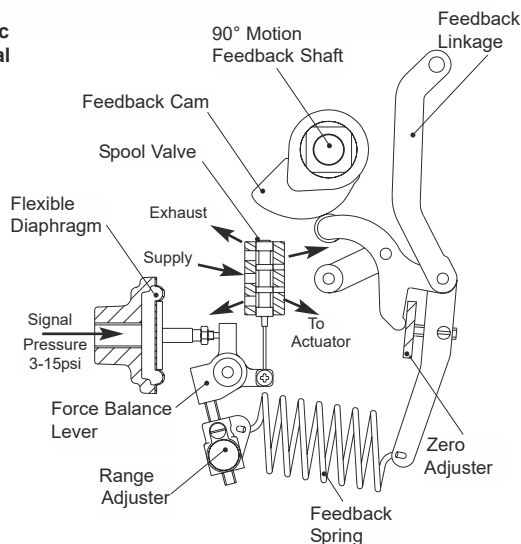

The AP positioner moves an actuator to a position set by a 3-15psi control signal and holds it there. Its features are:

- **Fast, smooth, accurate response**
- **Simple, all-mechanical function for unbeatable reliability**
- **Three flow options to optimise control on all actuator sizes**
- **Universal application**
The unit can be mounted in any orientation on to any quarter-turn or linear application
- **Easy set up**
Quick calibration and reversal of rotational sense (clockwise and counter clockwise) without special tools or parts change
- **ATEX CAT 1 / IECEx approved versions available**
- **Easily retrofitted integral module options include:**
 - Two wire 4-20mA angle retransmit (inside the same case)
 - Mechanical or inductive limit switches (general or hazardous areas)
 - 4-20mA I/P convertors (general or hazardous areas)
 - Clear Cone visual position indicator (general or hazardous areas)
 - DIN plug option for retransmit connection
 - Low (-40°C / -40°F) and high (100°C / 212°F) temperature versions available
 - Fail hold options available
 - Choice of mount options - see opposite
- **Weatherproof, compact and robust metal housing**
- **Vibration and shock resistant to 4G**
- **Built in ports for signal air supply and gauge connections**
- **ATEX CAT 2 Exd switch option available**

Kinetrol AP Positioner

The AP positioner can be directly mounted on standard Kinetrol models 05, 07, 08, 09, 10, 12, 14 and 15 actuators, both double acting and spring return, giving an assembly with no external plumbing, wiring or mechanical connections and the best in direct backlash free control. Mount kits are available for models 16, 18, 21, 30 and 60.

Alternatively, discrete versions mount on any actuator using VDI/VDE 3845 NAMUR drive, or Kinetrol male square with mounting brackets. Neat adaptations for linear cylinders are also available - consult Kinetrol for details.

Specification

| | |
|------------------------------------|--|
| Air Supply | instrument quality (dry, clean, oil free) 3.5 to 7 bar, (50 psi to 100 psi) standard. Consult Kinetrol for low pressure application |
| Signal | 3-15psi (0.2-1.0 bar) standard. Consult Kinetrol for split range, 6-30 psi etc. |
| Control Response | 0-90° linear output standard. Consult Kinetrol for other characteristic cam options |
| Sensitivity | better than 0.7% of span* |
| Hysteresis | better than 0.7% of span* |
| Deviation from linearity | less than 1% of span* |
| Flowrates @ 5.5 bar | AP: 3.3 scfm (93nl/min) MP: 10.0 scfm (283nl/min) HP: 27.0 scfm (764nl/min) |
| Operating Temperature Range | -20°C to +80°C (-4°F to +176°F) Standard -20°C to +100°C (-4°F to +212°F) High Temp -40°C to +80°C (-40°F to +176°F) Low Temp |
| Weight | 2.8 kg / 6.2 lb |
| Materials | <ul style="list-style-type: none"> case and cover - zinc alloy spool and liner - stainless steel diaphragm: <ul style="list-style-type: none"> - reinforced polyurethane (standard) - fluorocarbon rubber (high temp) - silicone rubber (low temp) feedback spring - steel |
| Finish | epoxy stove enamel |
| Enclosure Rating | IP54 |
| Output Torque | same as double acting or spring return actuator. When controlling fast movement of inertia loads consult Kinetrol |

* These refer to the combination of Kinetrol actuator with AP positioner - not just the positioner performance

Maximum Vibration Tolerance 4G, 100Hz

I/P Converter Options - please see I/P data sheet

Travel Times

Maximum velocity (no load) at 5.5 bar / 80 psi

| Model | 05 | 07 | 08 | 09 | 10 | 12 | 14 | 15 |
|---------|-----|----|----|----|----|----|------|-----|
| Deg/Sec | 180 | 90 | 53 | 45 | 33 | 25 | 10.6 | 6.0 |

*Externally piped from AP positioner to actuator

| Model | 12* | 14* | 15* | 16* | 18* | 21* | 30* | 60* |
|---------|-----|------|-----|------|------|-----|-----|-----|
| Deg/Sec | 32 | 13.8 | 7.5 | 22.5 | 11.3 | 5.9 | 3.8 | 1.9 |

Cam Options

Giving typical control characteristics. Contact Kinetrol for details of other options or see TD112.

| Air Signal | Electrical Signal | Output Movement | Characteristic | Cam No. |
|-------------------------|-------------------|-----------------|-------------------|---------|
| 3-15 psi 0.2-1.0 bar | 4-20mA | 0-90° | Linear | 5-1A |
| 3-9psi 0.2-0.6 bar | 4-12mA | 0-90° | Linear | 5-2A |
| 6-12 psi 0.4-0.8 bar | 8-16mA | 0-90° | Linear | 5-3A |
| 9-15psi 0.6-1.0 bar | 12-20mA | 0-90° | Linear | 5-4A |
| 3-15 psi 0.2-1.0 bar | 4-20mA | 0-60° | Linear | 5-5A |
| 3-15 psi 0.2-1.0 bar | 4-20mA | 0-45° | Linear | 5-6A |
| 3-15 psi 0.2-1.0 bar | 4-20mA | 0-90° | Proportional Flow | 5-7A |
| 3-9 psi 0.2-0.6 bar | 4-12mA | 0-90° | Proportional Flow | 5-8A |
| 9-15 psi 0.6-1.0 bar | 12-20mA | 0-90° | Proportional Flow | 5-22A |
| 3-12 psi 0.2-0.8 bar | 4-16mA | 0-90° | Linear | 5-13A |
| 9-15 psi 0.6-1.0 bar | 12-20mA | 0-60° | Linear | 5-14A |

Ordering Codes

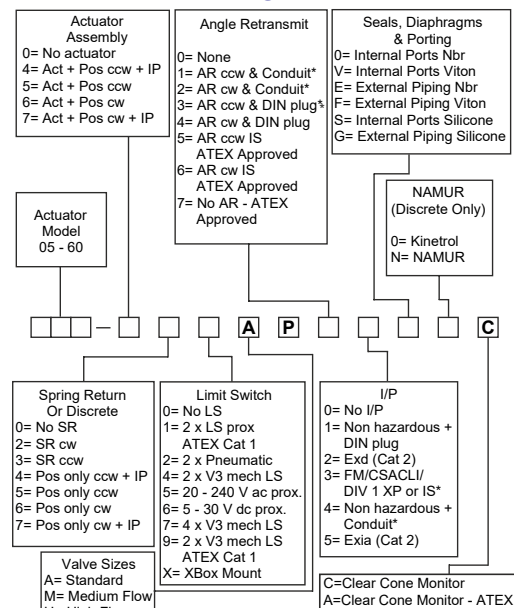

* Not available with ATEX approval
* 'A' Valve is supplied with all sizes up to and inc' 09
* 'M' Valve is supplied with 10-15
* 'H' Valve is supplied with sizes 16-60

UNLESS SPECIFICALLY REQUESTED OTHERWISE Recommended spring unit for model 14 actuator is 4900 type. This should be coded 12□49AP or 13□49AP instead of the usual 12□AP or 13□AP. The same applies to other specially coded spring assemblies.



Kinetrol AP Positioner

Modular Mounting Arrangement

NOTE: Model 05 Actuators are the smallest size actuator available with an AP Positioner

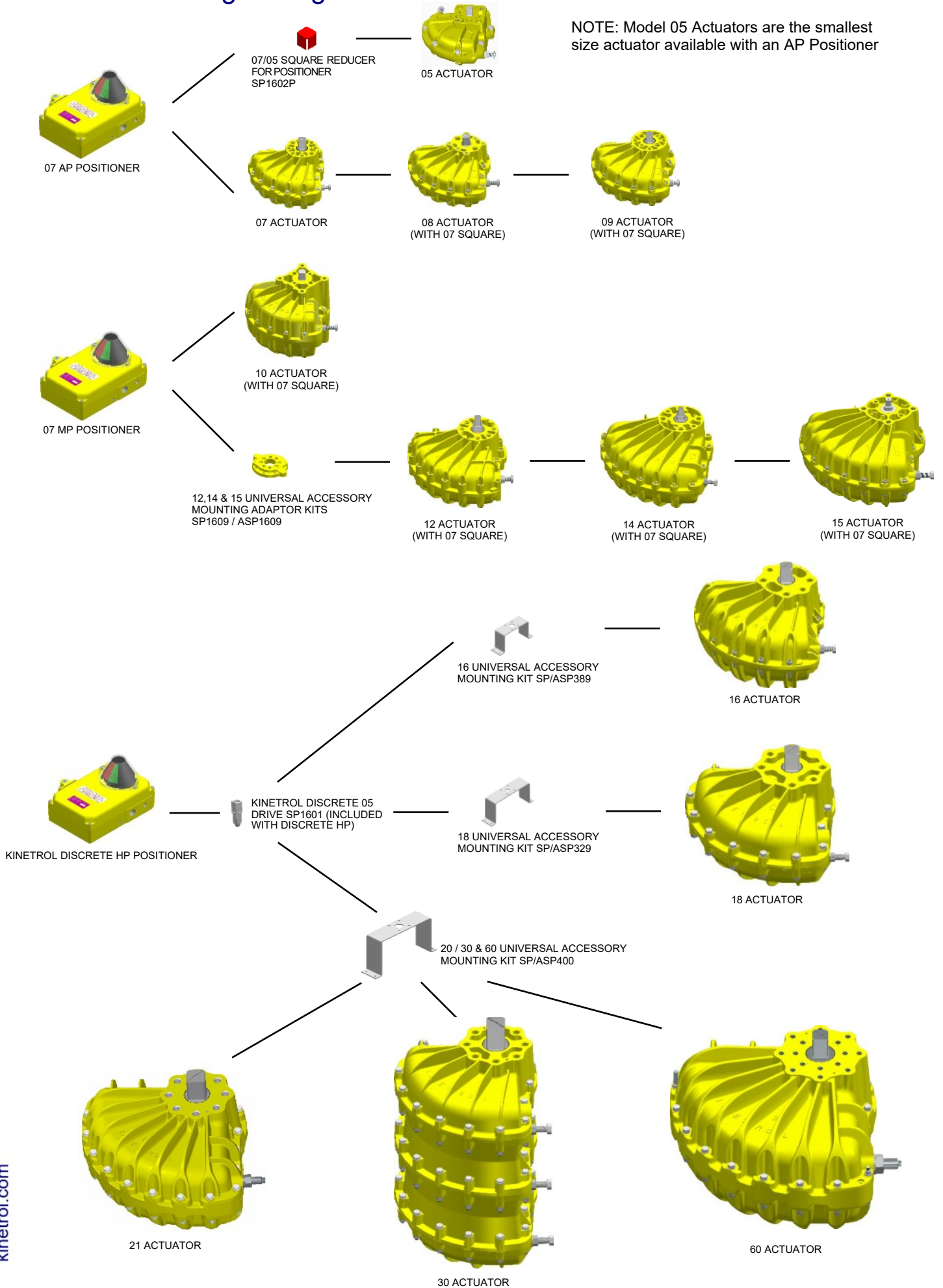

Kinetrol AP Positioner

AP Positioner Dimensions

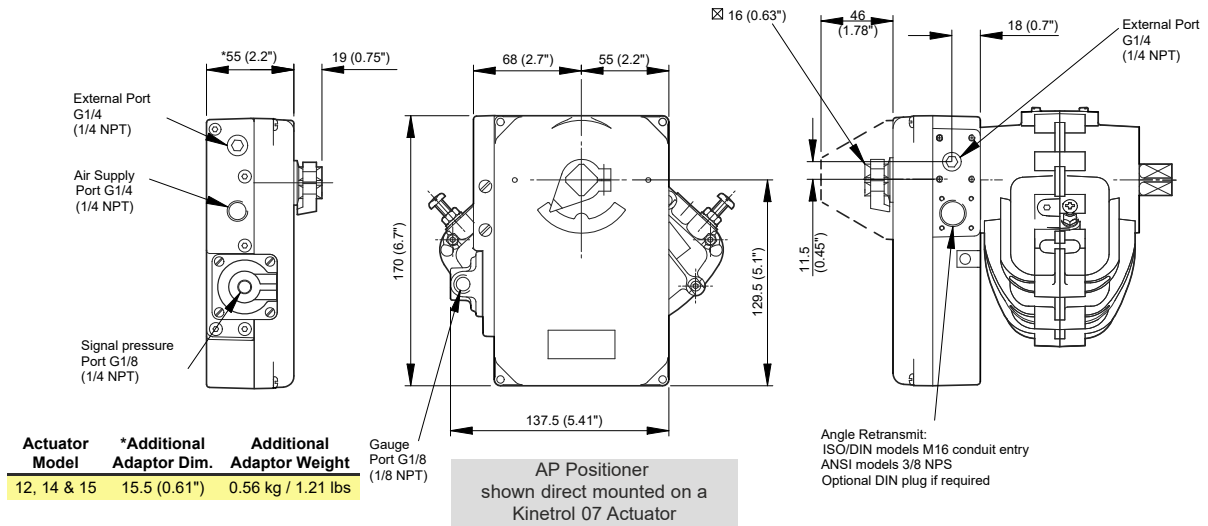

Namur Discrete Version

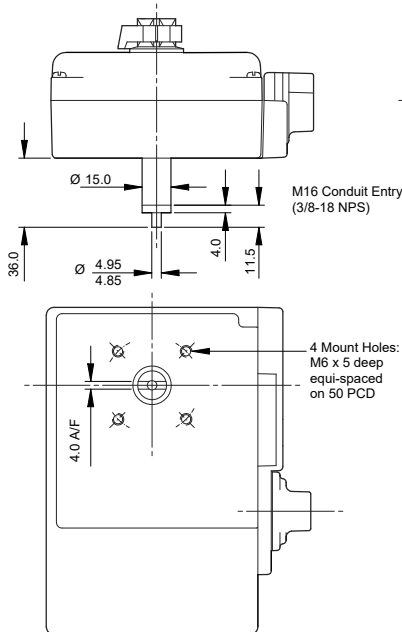

Non-Hazardous I/P Version

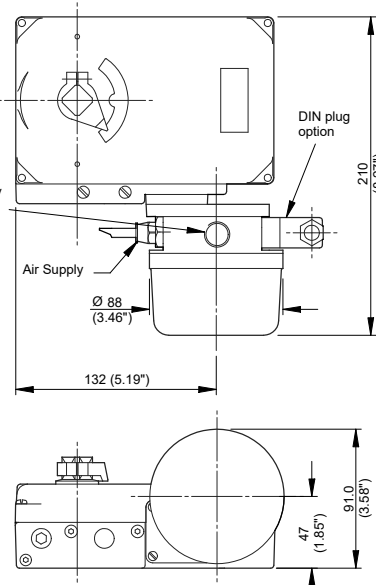

Kinetrol Discrete/ High Flow Version

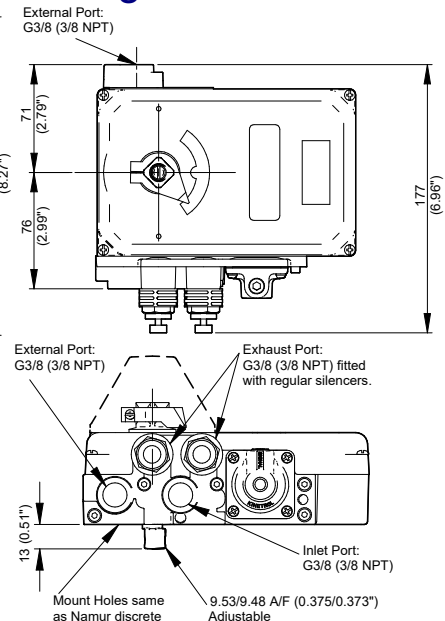

Explosion Proof I/P Version

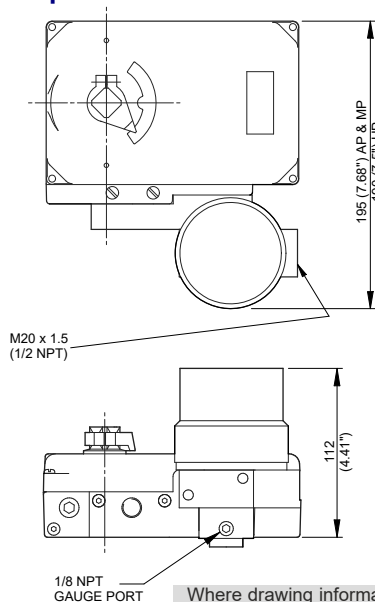

Switch Box Version

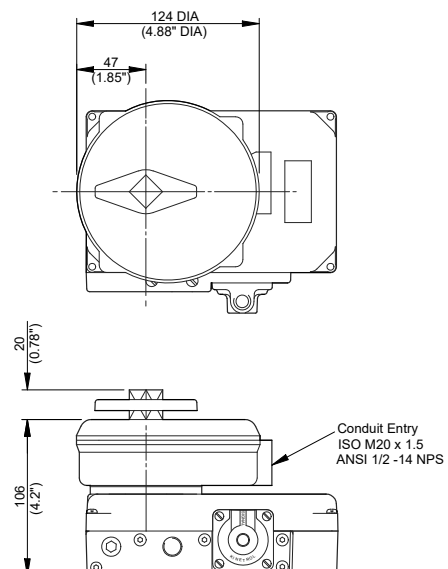

Where drawing information is not given - it is the same as the direct mount version