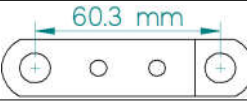

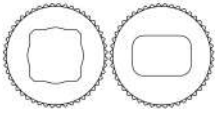



Table 1 Model	Yield temperature	Ambient temperature range	Fusible link type
05/07++0*0-1201	72°C	-40°C to 42°C	 Type "A"
05/07++0*0-1204	93°C	-40°C to 63°C	Pre 02.2019
05/07++0*0-0074	74°C	-40°C to 38°C	 Type "B"
05/07++0*0-0100	100°C	-40°C to 66°C	Post 02.2019

KEY: ++ Will be one of the following:
 4 - / 0 - = ISO Male Drive
 3F = ISO Female Drive
 7 - /9 - = ANSI Male Drive
 7F = ANSI Female Drive
 3S = ISO Serrated Female Drive**
 7S = ANSI Serrated Female Drive**

* Will be one of the following:
 2 = Clockwise spring action
 3 = Anticlockwise spring action

 **Typical serrated inserts

WARNING – KEEP OUT OF SHADED ZONE SHOWN BELOW DURING LOADING AND IN USE.

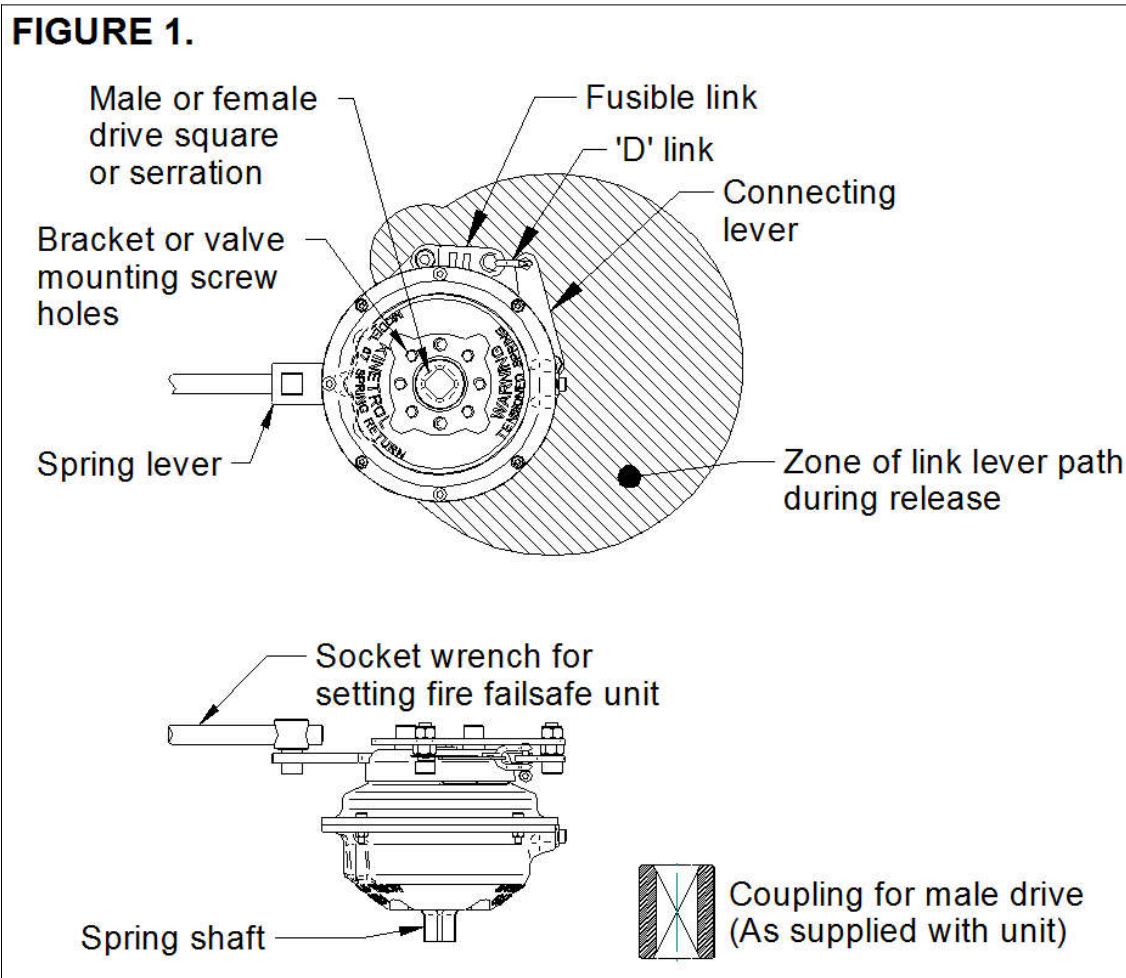



1.) INSTALLATION

- 1.1) Fit unit to bracket/valve with coupling to valve stem (unless a female drive version is used which can be directly connected to valve).
- 1.2) Ensure that coupling (if fitted) can be moved without much effort, such that it does not side load valve stem or spring shaft.
- 1.3) Refer to Kinetrol TD111 for recommended screw tightening torques.
- 1.4) Ensure that the unit is installed in a position which allows a socket wrench to be used to load the fail-safe link.
- 1.5) If serrated drive is used – use a Kinetrol insert to provide drive to valve.
- 1.6) Fail-safe link should not be painted or covered and be free from grease and dirt
- 1.7) Ensure unit is earthed.

2) OPERATION

- 2.1) Operating conditions:
 - Angle of travel 90° (Non-Adjustable)
 - Max vibrating conditions: 4g@100Hz
 - Fail safe yield temperature: and ambient temperature range: See table 1.
- 2.2) Load Fire Fail-safe by inserting a suitable socket wrench into square of the lever.
- 2.3) Rotate socket wrench slowly with a good grip and ensure that there is nothing in the path of an accidentally released lever. **DO NOT RELEASE THE WRENCH SUDDENLY DURING LOADING, AS THIS MAY RESULT IN INJURY OR DAMAGE.** Insert the 'D' link through the link lever and tighten. Gently release the wrench and remove from square.
- 2.4) The link is now loaded. To removed the link tension, follow this procedure in reverse.

3) MAINTENANCE

- 3.1) The Fire Fail-safe link should be inspected twice annually and renewed annually. Fire Fail-safe link can be replaced by removing the link tension (as described in 2.3) and removing the pivot pin. A suitable replacement can be obtained from Kinetrol.
Quote serial number as printed on spring label, and temperature and type “A” or type “B” from table 1.
Kinetrol document TD 221 specifies the fusible link and connecting lever combination required for replacement.
- 3.2) If the spring operation has to be checked it must be done as follows:
Insert a suitable socket wrench into square of the lever, pull against spring action until fire fail-safe link can be disconnected, then SLOWLY allow the spring to unwind until the spring lever locates on the travel stop.
DO NOT RELEASE THE WRENCH SUDDENLY, AS THIS MAY RESULT IN INJURY OR DAMAGE. The same safety precautions should be applied to releasing the unit as to latching it in position.
- 3.3) The spring unit does not contain user serviceable components. If the spring is faulty it should be disposed of safely and replaced with a new unit or returned to Kinetrol for repair.
- 3.4) Ensure any build-up of dust is removed and regular checks are made.

4) MATERIALS OF CONSTRUCTION

Spring housing – Aluminium Alloy Epoxy stove enamel,
Fusible link (Type B) – Bronze with eutectic alloy solder.
Cover plate and link lever – Stainless steel.