



Installation and Operating instructions for Kinetrol Geared Manual Overrides

Sizes 05 - 14

INSTALLATION: Unless otherwise specified the Geared Manual Override will be fitted with a right hand handwheel. There is a left hand option which must be requested upon order, the orientation is **NOT** interchangeable so ensure the correct option is ordered. If it is required to switch the orientation, first consider rotating the unit by 180°, if this is not achievable, it is possible to order spare parts to make a conversion from right hand handwheel to left hand or vice versa.

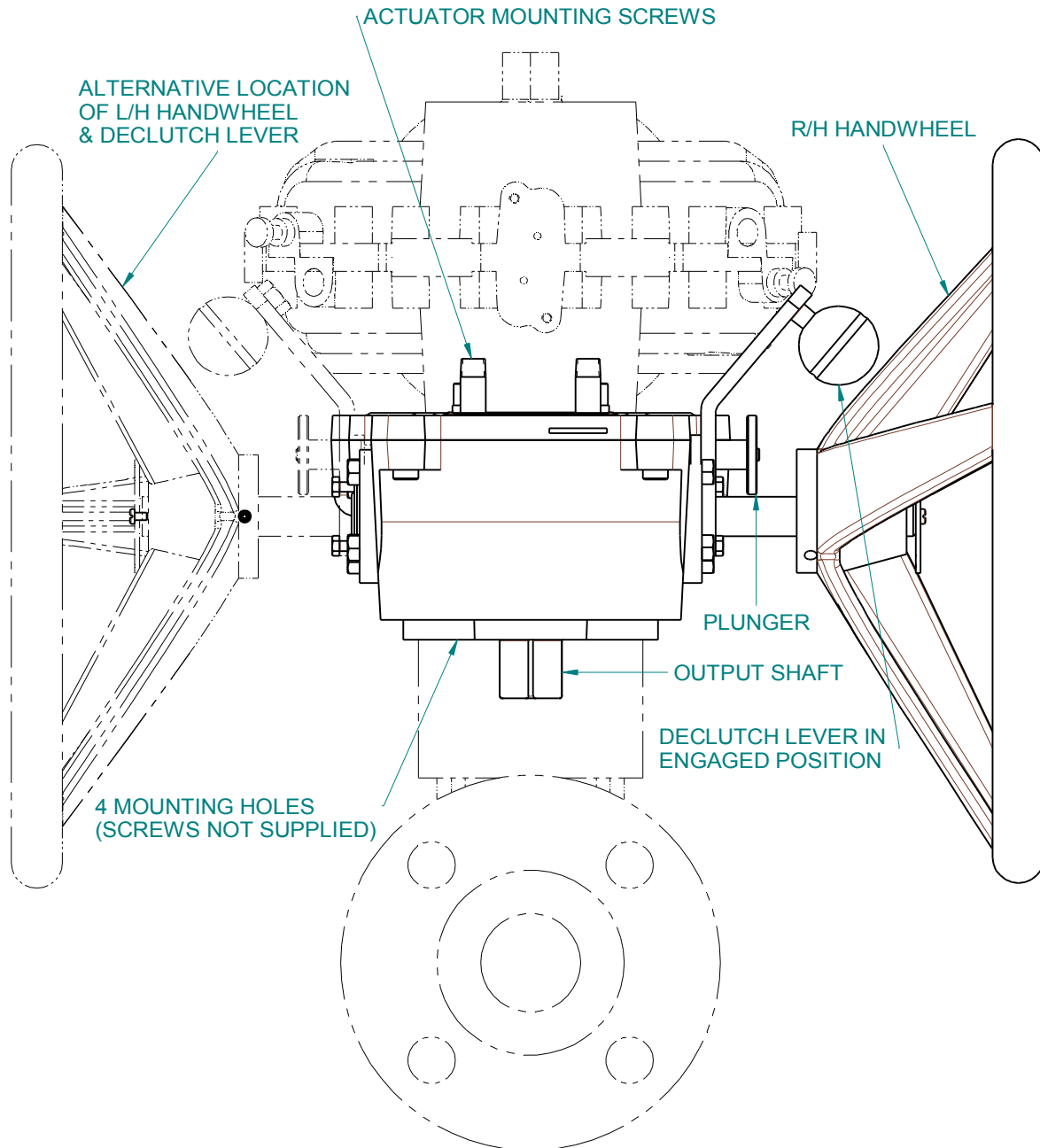

FIGURE 1.

MOUNTING: The assembly must be fitted between the output of the actuator assembly and the input shaft of the load (e.g. valve stem).

Issue	Signed	Date
E	G.C.N.	23/09/20

KINETROL Trading Estate Farnham Surrey England

Doc. No. TD185
Page 1 of 6



FITTING GEARBOX TO ACTUATOR: Firstly, ensure that the declutch lever is latched in the “Handwheel Engaged” position. This is recommended, else the actuator could move when attempting to assemble with gearbox. It is important that the valve, actuator and gearbox shafts are correctly aligned during assembly, and it is recommended that they are installed in their mid-travel position, eliminating the possibility of one component being in the incorrect orientation.

- 1) Remove the 6 base plate screws.
- 2) For all actuator models except 05 and 07, fit dowels into the actuator. Assemble base plate to actuator with four screws and chemically bond with thread locking fluid (Loctite 222 recommended) and tighten the screws to recommended torque (see Kinetrol Technical Data Sheet TD111). (Note 1. The 05 actuator model, has an additional adapter plate.)
- 3) Disengage the clutch then rotate the output shaft inside the housing until it lines up with the actuator square.
- 4) Refit the housing assembly to the base plate and screw the 6 base plate screws and chemically lock with thread locking fluid (again Loctite 222 recommended). Tighten the 6 screws to a torque of 6.3 Nm (56 lbf.in.).

FITTING THE HANDWHEEL: For some gearboxes, the handwheel will be despatched loose with the unit, along with the retaining pin taped to it.

- 1) The handwheel fits to the handwheel shaft with holes to insert the retaining pin.
- 2) Fit the handwheel label onto the shaft with the screw, ensuring it is the correct way round as these are double-sided.

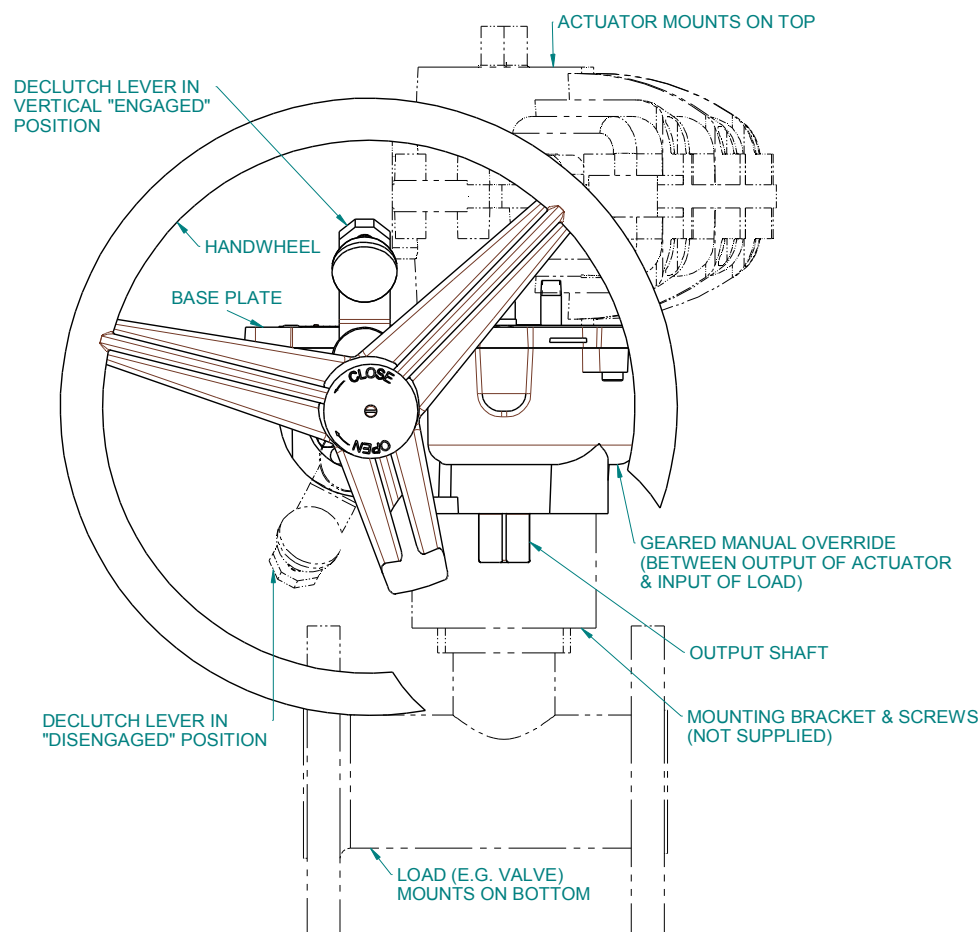

FIGURE 2.



OPERATING: Do not operate the Geared Manual Override unless the valve/pipeline is in a safe condition, or if a drive lever is installed (e.g. a damper drive) ensure suitable safety guarding is installed. Failure to observe may result in injury.

MOVING THE DECLUTCH LEVER: To move the declutch lever, first pull the declutch knob to extract the plunger from its locating hole; After turning declutch lever to the required position, ensure that the plunger is fully latched into its locating hole. To Engage the handwheel, it may be necessary to slowly rotate the handwheel until gear teeth are aligned. **DO NOT** attempt to select “engaged” lever position while the actuator is in motion (i.e. the actuator and its output are turning); Likewise, **DO NOT** attempt to “disengage” the declutch lever if the actuator air supply, or spring return if fitted, is set such that it is likely to cause the actuator to turn, thus applying a force through the manual override gears. Failure to observe the above may seriously damage the unit. If a spring return is fitted, it is recommended that a limit switch is fitted to provide feedback indicating the position of the declutch lever, thus ensuring that the declutch lever is in a safe position. Consult Kinetrol for details.

MANUAL OPERATION (using handwheel) : To operate the assembly manually, the Declutch lever must be latched in the “Handwheel Engaged” position. When unit has “Right Hand” Handwheel (see Figure 3 below), clockwise rotation of handwheel produces counter-clockwise rotation of actuator/output when viewed from arrow “A”. When the handwheel is fitted to the “Left Hand” side, clockwise rotation of handwheel produces clockwise rotation of shaft when viewed from arrow “A”.

PNEUMATIC OPERATION (using actuator): The declutch lever must be latched in the “Handwheel Disengaged” position.

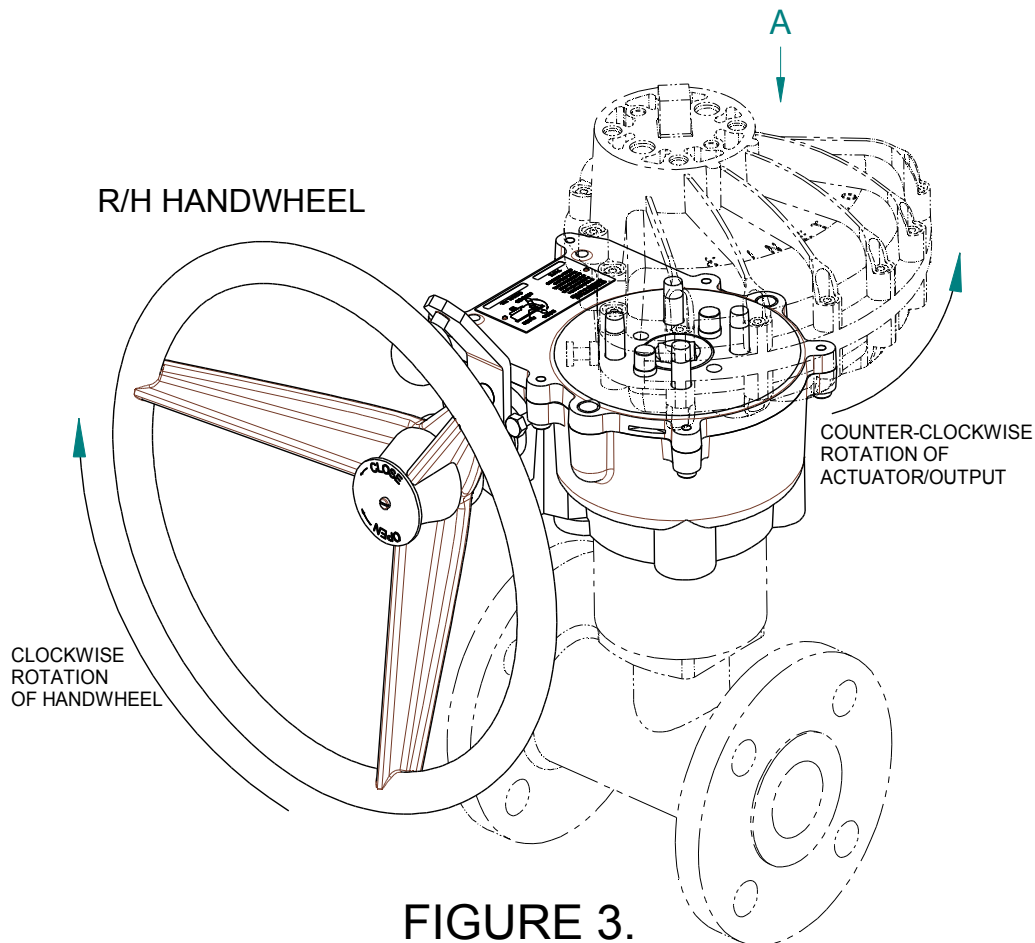

FIGURE 3.



Installation and Operating instructions for Kinetrol Geared Manual Overrides

Sizes 05 - 14

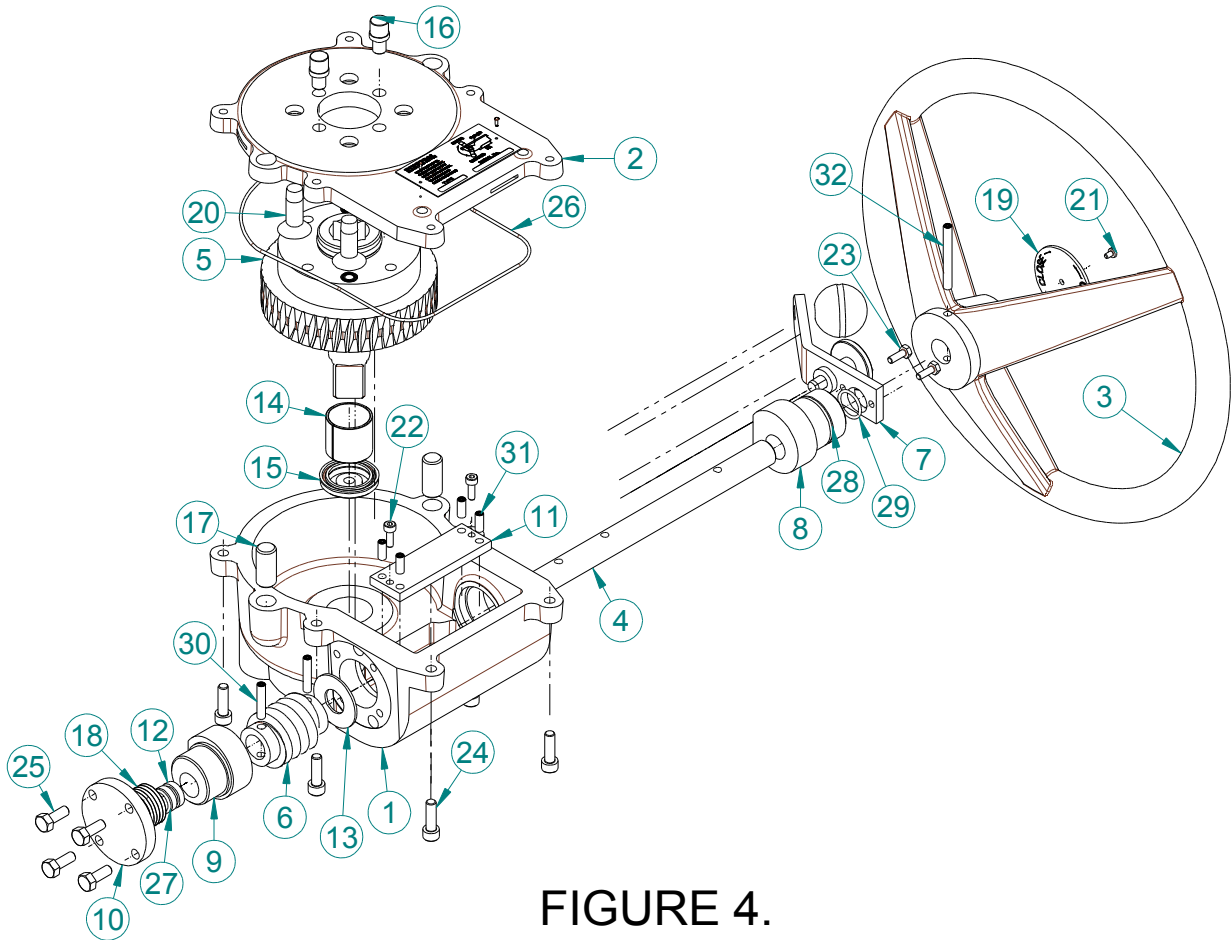

FIGURE 4.

Item Number	Item Description	Quantity	Item Number	Item Description	Quantity
1	Housing	1	17	Dowel	2
2	Base Plate	1	18	Shim	6
3	Handwheel	1	19	Handwheel Label	1
4	Handwheel Shaft	1	20	Actuator Mounting Screw	4
5	Wormwheel & Output Shaft	1	21	M3 x 5	1
6	Worm	1	22	M4 x 12 Socket Head	2
7	Declutch Lever	1	23	M4 x 12 Hex. Head	2
8	Long Eccentric Bearing	1	24	M6 x 20	6
9	Short Eccentric Bearing	1	25	M6 x 16 Hex. Head	4
10	Gearbox End Plate	1	26	O-ring	1
11	Tie Bar	1	27	O-ring	1
12	Thrust Pad	1	28	O-ring	1
13	Thrust Washer	1	29	O-ring	1
14	Bush	1	30	Spring Pin	2
15	Shaft Seal	1	31	Spring Pin	4
16	Dowel	2	32	Retaining Pin	1

TABLE 1.



MAINTENANCE:

IMPORTANT: Maximum recommended handwheel rim force and input torques are shown in Table 2, below. Applying excess input torque could seriously damage the gearbox, actuator and/or valve. **DO NOT** exceed these figures (e.g. by the use of extra levers on the handwheel to increase the handwheel torque) as this may seriously damage the unit. It is also very important that the position of the valve is known before turning the handwheel, as applying extra force to close an already closed valve will damage the unit.

Actuator Model	Safe Input Torques (Nm)	Safe Rim Force (N)	Safe Rim Force (lbf)
05 – 100	6.94	23.1	5.2
07 – 100	17.05	56.8	12.8
084 – 100	27.32	91.1	20.5
09 – 100	35.89	119.6	26.9
10 – 100	57.20	190.7	42.9
12 – 100	79.06	263.5	59.2
14 – 100	189.06	472.7	106.3

TABLE 2.

REMOVING ACTUATOR: Removal is basically the reverse of fitting. It is recommended that the handwheel is engaged before the actuator is removed.

DISASSEMBLY OF THE GEARBOX: The gearbox is maintenance free. However, if it is necessary to dismantle the gearbox for any reason. It is vital to note the location and orientation of all the components, particularly the 2 brass eccentric bearings, thrust washer, thrust pad and shims.

- 1) Unscrew the 6 screws on the base plate to remove it from the housing.
- 2) Move the declutch lever to the “gearbox disengaged” position and remove the wormwheel and output shaft assembly.
- 3) Unscrew the screws on the end plate to remove it from the housing, be careful as there may be shims placed in the end plate which may fall out.
- 4) Remove the thrust pad from the short eccentric bearing.
- 5) Spring pins attaching the tie bar to the eccentric bearings, and attaching the worm to the handwheel shaft must be removed using a suitable punch. Any further dismantling of the gearbox requires removing the pins.
- 6) Remove the tie bar linking the 2 eccentric bearings.
- 7) Slide the handwheel shaft out of the worm, bearings and the housing.
- 8) Remove the worm and thrust washer from between the eccentric bearings.
- 9) Unscrew the screws attaching the declutch lever to remove it from the eccentric bearing.
- 10) Remove the 2 eccentric bearings from the housing.



ASSEMBLY OF THE GEARBOX:

- 1) Grease the shaft seal and fit it into the housing.
- 2) Assemble the longer eccentric bearing with a greased O-ring, whilst the shorter eccentric bearing has no O-ring.
- 3) Assemble the declutch lever to the eccentric bearing with the hex. head screws, chemically bond the screws with thread locking fluid (Loctite 222 recommended) and tighten the screws to 3 Nm (25 lbf.in.).
- 4) Fit the worm and thrust washer at the correct end between the eccentric bearings, then grease an O-ring and fit into the groove in the longer bearing. Push shaft through the bearings and worm, lining up the holes in the worm and shaft, then carefully knock in both the retaining pins into the holes. Check that the declutch lever is in the vertical “gearbox engaged” position.
- 5) Fit the tie bar to the 2 eccentric bushes with dowels and screws, chemically bond with thread locking fluid (Loctite 222 recommended) and tighten the screws to 5 Nm (45 lbf.in.).
- 6) Grease an O-ring and assemble it into the thrust pad, then push the thrust pad into the short eccentric bearing. Grease and place shims into the end plate, add as many as required to eliminate or reduce as much as possible the movement of backlash.
- 7) Assemble the end plate to the housing with screws and Silastic, chemically bond with thread locking fluid (Loctite 222 recommended) and tighten screws to 11 Nm (95 lbf.in.).
- 8) Fit dowels into the housing and apply Permabond A126 to chemically lock the dowels into only the housing.
- 9) Move the declutch lever to the “gearbox disengaged” position and fit the output shaft assembly.
- 10) Liberally grease the teeth before packing the area around the worm and wormwheel then move the declutch lever to engage the worm with the wormwheel.
- 11) Place screws into the base plate before assembling the base plate to the housing with the 6 screws. Apply thread locking fluid to the screws.

NOTES RELATING TO ATEX APPROVED UNITS

- 1) Certain versions are certified ATEX category 2. Such units are identified by a label (see below) located on the base plate. If no such label is present, the unit is not ATEX approved.

<div style="display: flex; justify-content: space-between;"> <div style="border: 1px solid black; padding: 2px;"> <p>KINETROL 20 ATEX 0118 II 2G Ex h IIC T5 Gb II 2D Ex h IIC T90°C Db -40°C ≤ Ta ≤ 80°C</p> </div> <div style="border: 1px solid black; padding: 2px;"> <p>TYPE: XXX-XXX Ser. No: xxxxxxxxx</p> </div> </div>	<div style="display: flex; justify-content: space-between;"> <div style="border: 1px solid black; padding: 2px;"> <p>KINETROL 20 ATEX 0118 II 2G Ex h IIC T4 Gb II 2D Ex h IIC T110°C Db -20°C ≤ Ta ≤ 100°C</p> </div> <div style="border: 1px solid black; padding: 2px;"> <p>TYPE: XXX-XXX-2100 Ser. No: xxxxxxxxx</p> </div> </div>	<div style="display: flex; justify-content: space-between;"> <div style="border: 1px solid black; padding: 2px;"> <p>KINETROL 20 ATEX 0118 II 2G Ex h IIC T6 Gb II 2D Ex h IIC T70°C Db -54°C ≤ Ta ≤ 60°C</p> </div> <div style="border: 1px solid black; padding: 2px;"> <p>TYPE: XXX-XXXW Ser. No: xxxxxxxxx</p> </div> </div>
---	--	--

Normal Temperature

Assemblies fitted with the above label, for use at normal temperatures, are suitable for use in Hazardous Areas as stated on the label

High Temperature

Assemblies fitted with the above label, for use at higher temperatures, are suitable for use in Hazardous Areas as stated on the label

Low Temperature

Assemblies fitted with the above label, for use at lower temperatures, are suitable for use in Hazardous Areas as stated on the label. Available for size 08 and above only.

- 2) If the assembly is fitted with auxiliary modules, such as limit switch box, clear cone monitor or positioner, these modules may be certified, possibly to a different level of approval, specific to that module. Refer to the label and I.O.M. Instructions for that module.

- 3) The Geared Manual Overrides can be used in indoor or outdoor environments, within the temperature range specified on the label as shown in note 1, above.